



# TADANO

## TR-800XXL-4

80 Ton Capacity (72.6 Metric Tons)

### HYDRAULIC ROUGH TERRAIN CRANE

#### DIMENSION

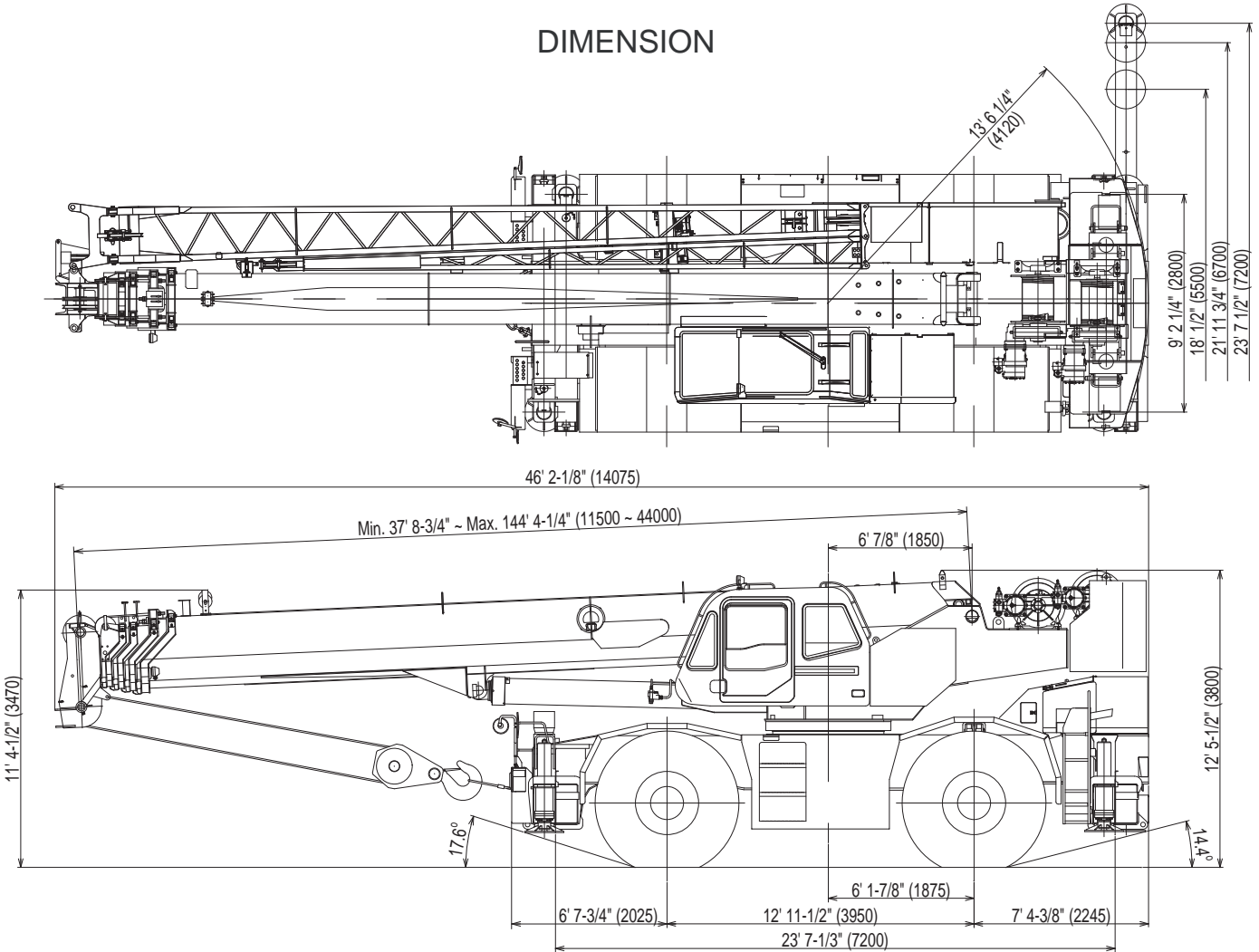

#### GENERAL DIMENSION (29.5 - 25 Tires)

	Feet	Meters
Turning radius		
4 wheel steer	21' 11-3/4"	6.7
2 wheel steer	39' 1/2"	11.9

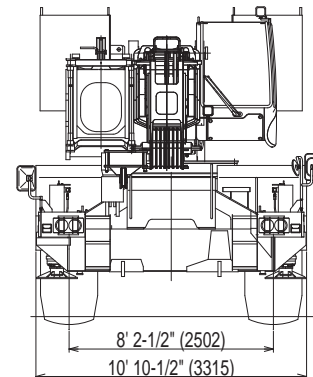

Specifications are subject to change without notice.  
Specification effects with S/No.545961 after.

# SUPERSTRUCTURE SPECIFICATIONS

## BOOM

Five section full power synchronized telescoping boom 37.7'~144.4' (11.5m~44.0m), of round hexagonal box construction with 7 sheaves, 15" (0.38m) root diameter, at boom head. The synchronization system consists of two double acting telescope cylinders, an extension cable and retraction cable Hydraulic cylinder fitted with holding valve. Two easily removable wire rope guards, rope dead end provided on both sides of boom head. Boom telescope sections are supported by wear pads both vertically and horizontally  
Extension speed 106' 7-1/2" in 145 seconds.

**BOOM ELEVATION** - By a double acting hydraulic cylinder with holding valve. Elevation -2.0°~80.7°, combination controls for hand or foot operation. Boom angle indicator. Automatic speed reduction and soft stop function.  
Elevation speed -2.0°~80.7° in 77 seconds.

**JIB** - Two stage bi-fold lattice type with 3.5°, 25° or 45° offset (tilt type). Single sheave, 15-5/8"(0.396m) root diameter, at the head of both jib sections. Stored alongside base boom section Jib length is 32.5' (9.9m) or 58.1' (17.7m). Assist cylinders for mounting and stowing are controlled at right side of superstructure. Self stowing jib mounting pins.

**AUXILIARY LIFTING SHEAVE (SINGLE TOP)**  
Single sheave, 15-5/8"(0.396m) root diameter. Mounted to main boom head for single line work (stowable)

**ANTI-TWO BLOCK** - Pendant type over-winding cut out device with audio-visual (FAILURE lamp/BUZZER) warning system.

**SWING**  
Hydraulic axial piston motor driven through planetary swing speed reducer. Continuous 360° full circle swing on ball bearing turntable at 2.3rpm. Equipped with manually locked/released swing brake. A 360° positive swing lock for pick and carry and travel modes, manually engaged in cab. Twin swing System: Free swing or lock swing controlled by selector switch on front console.

## HOIST

**MAIN HOIST** - Variable speed type with grooved drum driven by hydraulic axial piston motor through winch speed reducer. Power load lowering and raising. Equipped with automatic brake (neutral brake) and counterbalance valve. Controlled independently of auxiliary hoist. Equipped with cable follower and drum rotation indicator.

**DRUM** - Grooved 15-3/4"(0.40m) root diameter x 22-3/4" (0.578m) wide. Wire rope: 797' of 3/4"diameter rope (243m of 19mm). Drum capacity: 1,096' (334m) 7 layers. Maximum line pull (permissible): 15,200lbs. (6,880kg). Maximum line speed 585FPM (178m/min).

**AUXILIARY HOIST** - Variable speed type with grooved drum driven by hydraulic axial piston motor through winch speed reducer. Power load lowering and raising. Equipped with automatic brake (neutral brake) and counterbalance valve Controlled independently of main hoist. Equipped with cable follower and drum rotation indicator.

**DRUM** - Grooved 15-3/4"(0.40m) root diameter x 22-3/4" (0.578m) wide. Wire rope: 436' of 3/4"diameter rope (133m of 19mm). Drum capacity: 1,096' (334m) 7 layers. Maximum line pull (permissible): 15,200lbs. (6,880kg). Maximum line speed 585FPM (178m/min).

**WIRE ROPE** - Warrington seal wire, extra improved plow steel preformed, independent wire rope core, right regular lay 3/4"(19 mm) 6X37 class

## HOOK BLOCKS

60 ton (54.4 metric ton) - 5 sheaves with swivel hook and safety latch, for 3/4"(19mm) wire rope.(OPTIONAL)  
6.2 ton (5.6 metric ton) - Weighted hook with swivel and safety latch, for 3/4"(19mm) wire rope

## HYDRAULIC SYSTEM

**PUMPS** - Two variable piston pumps for crane functions Tandem gear pump for steering, swing and optional equipment Powered by carrier engine. Pump disconnect for crane is engaged/ disengaged by rotary switch from operator's cab

**CONTROL VALVES** - Multiple valves actuated by pilot pressure with integral pressure relief valves

**RESERVOIR** - 195 gallon (740 lit.) capacity. External sight level gauge.

**FILTRATION** - 26 micron return filter, full flow with bypass protection, located inside of hydraulic reservoir. Accessible for easy replacement.

**OIL COOLER** - Air cooled fan type.

## CAB AND CONTROLS

Both crane and drive operations can be performed from one cab mounted on rotating superstructure.

Left side, 1 man type, steel construction with sliding door access and tinted safety glass windows opening at side. Door window is powered control. Windshield glass window and roof glass window are shatter-resistant. Tilt-telescoping steering wheel. Adjustable control lever stands for swing, boom hoist boom telescoping, auxiliary hoist and main hoist. Control lever stands can change neutral positions and tilt for easy access into cab. 3 way adjustable operator's seat with high back, headrest and armrest. Engine throttle knob. Foot operated controls: boom hoist, boom telescoping, service brake and engine throttle. Hot water cab heater and air conditioning (OPTIONAL)

Dash-mounted engine start/stop, monitor lamps, cigarette lighter ashtray, drive selector switch, parking brake switch, steering mode select switch, power window switch, pump engaged/disengaged switch, swing brake switch, telescoping/auxiliary winch select switch, outrigger controls, main winch/auxiliary winch selector switch, swing stop cancel switch, slow elevation stop cancel switch, free swing / lock swing selector switch

Instruments - Torque converter oil temperature, engine water temperature, air pressure, fuel, speedometer, tachometer and hour meter. Hydraulic oil pressure is monitored and displayed on the AML-L display panel.

Tadano electronic LOAD MOMENT INDICATOR system (AML-L) including:

- Control lever lockout function with audible and visual pre-warning
- Lift status indicator
- Outrigger status indicator
- Boom angle / boom length / jib offset angle / load radius / rated lifting capacities / actual loads read out
- Ratio of actual load moment to rated load moment indication
- Automatic Speed Reduction and Soft Stop function on boom elevation and swing
- Working condition register switch
- Load radius / boom angle / tip height / swing range preset function
- External warning lamp

TADANO AML-L monitors outrigger extended length and automatically programs the corresponding "RATED LIFTING CAPACITIES" table.

## CARRIER SPECIFICATIONS

**TYPE** - Rear engine, left hand steering, driving axle 2-way selected type by manual switch, 4x2 front drive, 4x4 front and rear drive.

**FRAME** - High tensile steel, all welded mono-box construction

**TRANSMISSION** - Electronically controlled full automatic transmission. Torque converter driving full powershift with driving axle selector. 6 forward and 2 reverse speeds, constant mesh.

- 3 speeds - high range - 2 wheel drive; 4 wheel drive
- 3 speeds - low range - 4 wheel drive

**TRAVEL SPEED** - 24 mph (39 km/h)

**AXLE**- Front: Full floating type, steering and driving axle with planetary reduction. Rear: Full floating type, steering and driving axle with planetary reduction and non-spin rear differential

**STEERING**- Hydraulic power steering controlled by steering wheel. Four steering modes available: 2 wheel front, 2 wheel rear, 4 wheel coordinated and 4 wheel crab

### ENGINE

Model	Mitsubishi 6M60-TLA3B
Type	Direct injection diese
No. of cylinders	6
Combustion	4 cycle, turbo charged and after coole
BoreXStroke, in.(mm)	4.646 X 4.528 (118X115)
Displacement, cu. in (liters)	460 (7.54)
Air inlet heater	24 volt prehea
Air cleaner	Dry type, replaceable elemen
Oil filter	Full flow with replaceable elemen
Fuel filter	Full flow with replaceable elemen
Fuel tank, gal.(liters)	79.2 (300), right side of carrie
Cooling	Liquid pressurized, recirculating by-pass

Operator's right hand console includes transmission gear selector and sight level bubble. Upper console includes working light switch, roof washer and wiper switch, oil cooler switch, emergency outrigger set up key switch, drum indicator switch, jib equipped/removed select switch boom emergency telescoping switch (2nd and 3rd - top) and air conditioning control switch. Swing lock lever.

**NOTE** : Each crane motion speed is based on unladen conditions.

**SUSPENSION** - Front: Rigid mounted to frame. Rear: Pivot mounted with hydraulic lockout device.

**BRAKE SYSTEMS** - Service: Air over hydraulic disc brakes on all 4 wheels. Parking/Emergency: Spring applied-air released brake acting on input shaft of front axle. Auxiliary: Electro-pneumatic operated exhaust brake.

**TIRES** - 29.5-25 22PR(OR) or 29.5-25 28PR(OR)

**OUTRIGGERS** - Four hydraulic, beam and jack outriggers. Vertical jack cylinders equipped with integral holding valve. Each outrigger beam and jack is controlled independently from cab Beams extend to 23' 7-1/2" (7.2 m) center-line and retract to within 10' 10-1/2" (3.315 m) overall width with floats. Outrigger jack floats are attached thus eliminating the need of manually attaching and detaching them. Controls and sight bubble located in superstructure cab. Four outrigger extension lengths are provided with corresponding "RATED LIFTING CAPACITIES" for crane duty in confined areas. Both symmetrical and Non-symmetrical outrigger extension (deployment) is permitted

Min. Extension	9' 2-1/4" center to center
Mid. Extension	18' 1/2" center to center
Mid. Extension	21' 11-3/4" center to center
Max. Extension	23' 7-1/2" center to center

Float size(Diameter) 1' 7-11/16" (0.5m)

Radiator	Fin and tube core, thermostat controlle
Fan, in.(mm)	Suction type, 6-blade, 23.6 (600) dia.
Starting	24 volt
Charging	24 volt system, negative ground
Battery	2-120 amp. Hour
Compressor, air, CFM(l /min)	29 CFM (830) at 2,600rpm
Horsepower (kW)	Gross 267 (200) at 2,600rpm
Torque, Max. ft-lb (kgm)	579 (80) at 1,400rpm
Capacity, gal.(liters)	
Cooling water	3.4 (13)
Lubrication	3.4-4.0 (13-15)
Fuel	79.2 (300)

# STANDARD EQUIPMENT

- Five section full power partially synchronized boom 37.7'~144.4' (11.5 m~44.0 m)
- 32.5' or 58.1' (9.9 m or 17.7 m) bi-fold lattice jib (tilt type) with 3.5°, 25° or 45° pinned offsets and self storing pins.
- Auxiliary lifting sheave (single top) stowable
- Variable speed main hoist with grooved drum, cable follower and 797' of 3/4" cable.
- Variable speed auxiliary hoist with grooved drum, cable follower and 436' of 3/4" cable.
- Drum rotation indicator (thumper type) main and auxiliary hoist
- Anti-Two block device (overwind cutout)
- Boom angle indicator
- Tadano electronic load moment indicator system (AML-L)
- Outrigger extension length detector
- Electronic crane monitoring system
- Tadano twin swing system and 360° positive swing lock
- Self centering finger control levers with pilot control
- Control pedals for boom hoist and boom telescoping
- 3 way adjustable cloth seat with armrests, high back and seat belt
- Tilt-telescoping steering wheel
- Tinted safety glass and sun visor
- Front windshield wiper and washer
- Roof window wiper and washer
- Power window (cab door )
- Rear view mirrors (right and left side)
- Mirror for main and auxiliary hoists
- Cigarette lighter and ashtray
- Electric fan in cab
- Cab floor mat
- Pump disconnect in operator's cab
- Hydraulic oil cooler
- Independently controlled outriggers
- Four outrigger extension positions
- Self-storing outrigger pads
- Outrigger hose protection
- Mitsubishi 6M60-TLA3B turbo charged after cooled engine (267HP) with exhaust brake
- Electronic controlled automatic transmission driven by torque converter
- 4 X 4 X 4 drive/steer
- Non-spin rear differential
- Automatic rear axle oscillation lockout system
- 29.5-25 22PR (OR) tires or 29.5-25 28PR (OR) tires
- Disc brakes
- Fenders
- Air dryer
- Water separator with filter
- Engine over-run alarm
- Back-up alarm
- Low oil pressure/high water temp. warning device (visual)
- Rear steer centering light
- Air cleaner dust indicator
- Full instrumentation package
- Complete highway light package
- Work lights
- Tool storage compartment
- Tire inflation kit
- 24 volt electric system
- 6.2 ton (5.6 metric ton) hook with swivel
- Towing hooks-Front and rear
- Lifting eyes
- Hook block tie down (front bumper)
- Weighted hook storage compartment

# OPTIONAL EQUIPMENT

- 80 ton (72.6 metric ton) 7 sheave with swivel hook and safety latch for 3/4"(19mm) wire rope
- 50 ton (45.4 metric ton) 4 sheave with swivel hook and safety latch for 3/4"(19mm) wire rope
- Hot water cab heater and air conditioner

# HOISTING PERFORMANCE

## LINE SPEEDS AND PULLS

Layer	Speed	Main or auxiliary hoist - 15'-3/4" (0.4m) drum					
		Line speeds <sup>2</sup>		Line pulls			
				Available <sup>1</sup>		Permissible <sup>4</sup>	
		F.P.M	m/min	Lbs.	kgf	Lbs.	kgf
1st	High	378	115	18,200	8,260	15,200	6,880
2nd	High	413	126	16,700	7,570	13,900	6,310
3rd	High	448	136	15,400	6,990	12,800	5,820
4th	High	482	147	14,300	6,490	11,900	5,410
5th	High	502	157	13,400	6,060	11,100	5,050
6th	High	551	168	12,500	5,680	10,400	4,730
7th <sup>3</sup>	High	585	178	11,800	5,350	9,800	4,460

<sup>1</sup> Developed by machinery with each layer of wire rope, but not based on rope strength or other limitation in machinery or equipment.

<sup>2</sup> Line speeds based only on hook block, not loaded.

<sup>3</sup> Seventh layer of wire rope are not recommended for hoisting operations.

<sup>4</sup> Permissible line pull may be affected by wire rope strength.

## DRUM WIRE ROPE CAPACITIES

Wire rope layer	Main and auxiliary drum grooved lagging			
	3/4" (19mm) wire rope			
	Rope per layer		Total wire rope	
	Feet	Meters	Feet	Meters
1	123.0	37.5	123.0	37.5
2	134.2	40.9	257.2	78.4
3	145.3	44.3	402.6	122.7
4	156.5	47.7	559.1	170.4
5	167.7	51.1	726.7	221.5
6	178.8	54.5	905.5	276.0
7	190.0	57.9	1095.5	333.9

## DRUM DIMENSIONS

	Inch	mm
Root diameter	15-3/4"	400
Length	22-3/4"	578
Flange diameter	27-3/8"	695

# TR-800XXL WORKING RANGE CHART

Telescoping Mode I

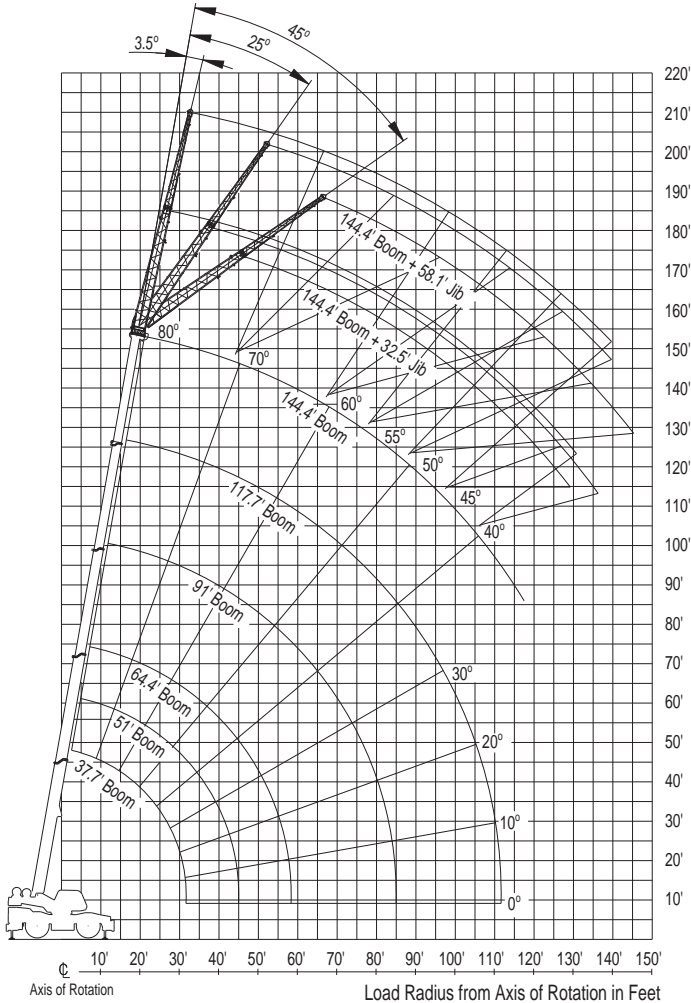

Boom Length in Feet (Telescoping Mode I)

Telescoping Mode II

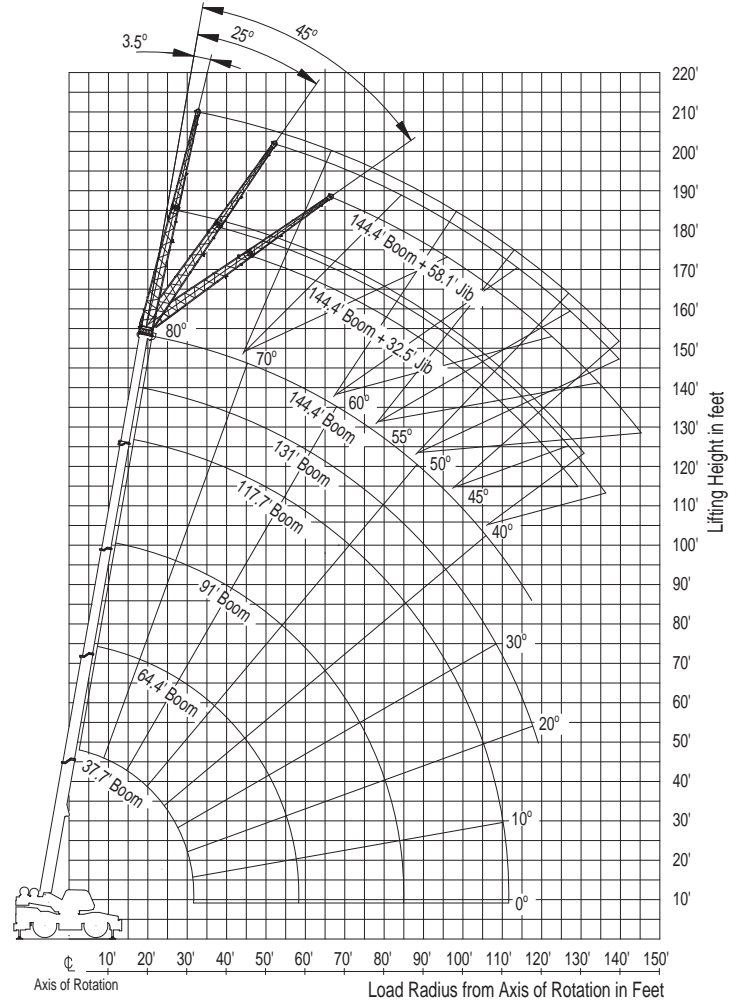

Boom Length in Feet (Telescoping Mode II)

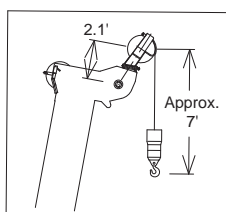
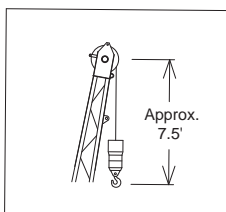
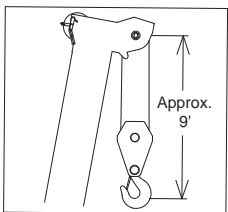
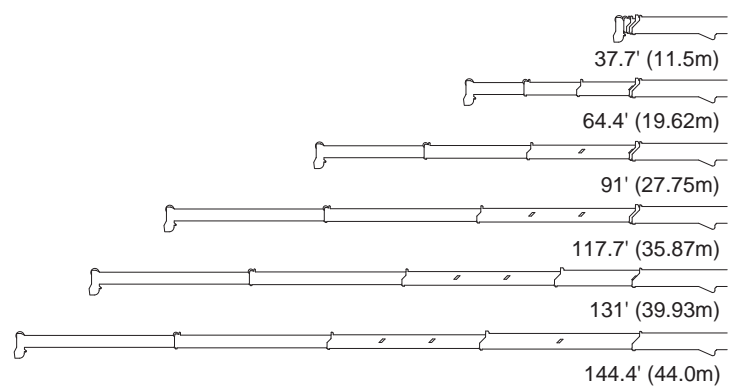
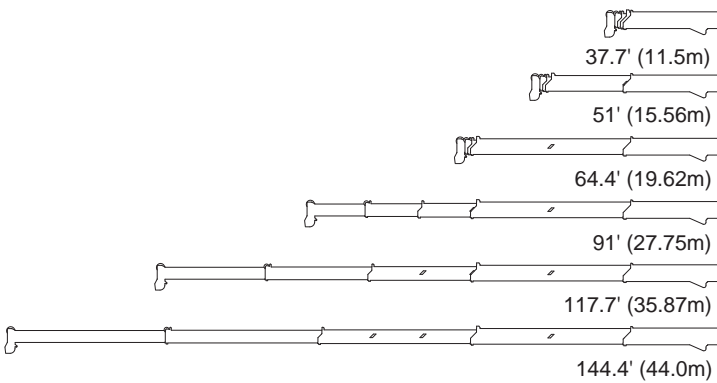

**NOTE :** Boom and jib geometry shown are for unloaded condition and machine standing level on firm supporting surface. Boom deflection and subsequent radius and boom angle change must be accounted for when applying load to hook.

# TR-800XXL RATED LIFTING CAPACITIES (IN POUNDS)

ON OUTRIGGERS FULLY EXTENDED 23' 7-1/2" (7.2m) SPREAD														
360° ROTATION														
A B	37.7'		51'		64.4' (19.62m)		91' (27.75m)		117.7' (35.87m)		131'		144.4'	
	C	(11.5m)	C	(15.56m)	C		C		C		C	(39.93m)	C	(44.0m)
10'	68°	160,000	75°	103,600	78°	88,100	78°	44,000						
12'	65°	125,000	72°	103,600	76°	88,100	76°	44,000						
15'	60°	108,000	69°	103,600	73°	88,100	73°	44,000	79°	44,000	79°	30,800		
20'	50°	78,400	63°	77,800	69°	71,900	69°	44,000	76°	44,000	76°	30,800	79°	30,800
25'	38°	59,400	56°	59,000	64°	56,100	64°	44,000	73°	44,000	73°	30,800	77°	30,800
30'	21°	45,900	48°	44,600	59°	42,600	59°	44,000	70°	39,000	70°	26,700	75°	30,800
35'			39°	33,800	53°	33,000	53°	39,900	66°	34,000	66°	23,200	72°	28,200
40'			28°	26,300	47°	25,500	47°	32,300	63°	28,700	63°	20,400	70°	24,700
45'			5°	20,900	40°	20,000	40°	26,400	59°	23,600	59°	18,200	67°	21,800
50'					32°	15,900	32°	21,900	55°	19,300	56°	16,400	65°	19,500
60'									46°	13,200	47°	14,500	59°	14,800
70'									36°	9,000	37°	11,400	53°	10,700
80'									22°	6,100	24°	9,500	46°	7,600
90'													38°	5,300
100'													27°	3,500
110'													13°	2,100
120'													19°	2,600
D	0°											18°	32°	
Telescoping conditions (%)														
Telescoping mode	I, II	I	I	I	II	I	II	I	II	I	II	II	I, II	
2nd boom	0	50	100	0	100	0	100	0	100	0	100	50	100	
3rd boom	0	0	0	33	33	66	66	100	100	100	100	100	100	
4th boom	0	0	0	33	33	66	66	100	100	100	100	100	100	
Top boom	0	0	0	33	33	66	66	100	100	100	100	100	100	

LIFTING CAPACITIES AT ZERO DEGREE BOOM ANGLE ON OUTRIGGERS FULLY EXTENDED																
23' 7-1/2" (7.2m) SPREAD 360° ROTATION																
A C	37.7'		51'		64.4'		64.4'		91'		91'		117.7'		117.7'	
	B	(11.5m)	B	(15.56m)	B	(19.62m)	B	(19.62m)	B	(27.75m)	B	(27.75m)	B	(35.87m)	B	(35.87m)
0°	31.7'	41,600	45.0'	20,900	58.3'	11,500	58.3'	14,900	85.0'	5,200	85.0'	7,900	111.6'	2,000	111.6'	4,300
Telescoping mode	I, II	I	I	I	II	I	II	I	II	I	II	I	II			

- A :Boom length in feet
- B :Load radius in feet
- C :Loaded boom angle (deg.)
- D :Minimum boom angle (deg.) for indicated length (no load)

NOTE: -The lifting capacity data stored in the LOAD MOMENT INDICATOR (AML-L) is based on the standard number of parts of line listed in the chart.

-Standard number of parts of line for outrigger operation should be according to the following table.

Boom Length in Feet (meters)	37.7' (11.5m)	37.7' to 51' (11.5m to 15.56m)	51' to 64.4' (15.56m to 19.62m)	64.4' to 91' (19.62m to 27.75m)	91' to 144.4' (27.75m to 44.0m)	Single top Jib
Number of parts of line	16	12	10	5	4	1

# TR-800XXL RATED LIFTING CAPACITIES (IN POUNDS)

ON OUTRIGGERS FULLY EXTENDED 23' 7-1/2" (7.2m) SPREAD 360° ROTATION													
C	144.4' (44.0m) Boom + 32.5' (9.9m) Jib						C	144.4' (44.0m) Boom + 58.1' (17.7m) Jib					
	3.5° offset		25° offset		45° offset			3.5° offset		25° offset		45° offset	
	R	W	R	W	R	W		R	W	R	W	R	W
80°	32.7'	9,900	44.5'	8,800	52.7'	8,100	80°	40.6'	5,900	64.3'	5,400	73.5'	3,400
75°	50.3'	9,900	61.2'	8,700	67.6'	7,300	75°	60.6'	5,900	82.5'	4,800	89.9'	3,400
70°	66.4'	9,700	75.9'	7,600	81.2'	6,600	70°	79.3'	5,900	98.7'	4,200	105.0'	3,400
65°	80.5'	7,900	89.3'	6,600	93.9'	6,000	65°	95.6'	4,900	114.0'	3,700	118.0'	3,100
60°	93.7'	6,300	102.0'	5,700	106.0'	5,400	60°	111.0'	4,100	126.0'	3,300	131.0'	2,900
55°	106.0'	5,100	113.0'	4,500	116.0'	4,300	55°	124.0'	3,100	141.0'	2,900	142.0'	2,700
50°	117.0'	3,500	124.0'	3,100	125.0'	3,000	50°	137.0'	2,100	151.0'	1,800	152.0'	1,700
45°	127.0'	2,200	133.0'	2,000	134.0'	2,000	45°	149.0'	1,200				
40°	137.0'	1,300	142.0'	1,200									

ON OUTRIGGERS FULLY EXTENDED 23' 7-1/2" (7.2m) SPREAD 360° ROTATION													
C	117.7' (35.87m) Boom (telescoping mode I) + 32.5' (9.9m) Jib						C	117.7' (35.87m) Boom (telescoping mode I) + 58.1' (17.7m) Jib					
	3.5° offset		25° offset		45° offset			3.5° offset		25° offset		45° offset	
	R	W	R	W	R	W		R	W	R	W	R	W
80°	26.1'	12,300	37.7'	11,000	44.8'	8,400	80°	33.6'	7,900	55.1'	5,700	67.0'	3,700
75°	40.1'	12,300	50.7'	10,000	57.0'	8,000	75°	50.4'	7,900	70.3'	5,200	80.7'	3,700
70°	53.6'	12,100	62.9'	8,800	68.5'	7,400	70°	65.9'	7,100	84.4'	4,700	93.1'	3,600
65°	65.7'	9,900	74.6'	7,700	79.0'	6,700	65°	80.2'	6,000	97.2'	4,200	104.0'	3,500
60°	76.9'	8,400	85.2'	6,800	88.9'	6,200	60°	93.5'	5,100	109.0'	3,800	114.0'	3,300
55°	87.6'	7,000	95.4'	6,000	98.2'	6,000	55°	106.0'	4,500	120.0'	3,500	124.0'	3,100
50°	97.5'	5,800	104.0'	5,200	106.0'	5,400	50°	117.0'	3,900	130.0'	3,200	132.0'	3,000
45°	106.0'	4,300	113.0'	4,000	114.0'	4,200	45°	127.0'	2,900	138.0'	2,600	140.0'	2,600
40°	115.0'	3,200	120.0'	3,000			40°	136.0'	2,000	146.0'	1,800		
35°	122.0'	2,400	126.0'	2,300			35°	145.0'	1,300	153.0'	1,200		
30°	128.0'	1,700	132.0'	1,700									
25°	134.0'	1,200	137.0'	1,200									

ON OUTRIGGERS FULLY EXTENDED 23' 7-1/2" (7.2m) SPREAD 360° ROTATION													
C	117.7' (35.87m) Boom (telescoping mode II) + 32.5' (9.9m) Jib						C	117.7' (35.87m) Boom (telescoping mode II) + 58.1' (17.7m) Jib					
	3.5° offset		25° offset		45° offset			3.5° offset		25° offset		45° offset	
	R	W	R	W	R	W		R	W	R	W	R	W
80°	26.8'	11,000	39.1'	10,300	46.6'	8,300	80°	34.2'	6,300	56.8'	5,700	67.7'	3,700
75°	41.0'	11,000	52.3'	9,300	58.8'	7,700	75°	51.0'	6,300	71.7'	5,100	81.4'	3,700
70°	54.5'	10,600	64.5'	8,000	70.1'	6,900	70°	67.0'	6,300	85.4'	4,400	93.8'	3,600
65°	66.3'	8,600	75.9'	7,000	80.4'	6,200	65°	80.9'	5,300	98.4'	3,900	105.0'	3,300
60°	77.6'	7,100	86.6'	6,200	90.2'	5,700	60°	94.2'	4,500	110.0'	3,500	115.0'	3,000
55°	88.4'	5,900	96.5'	5,300	98.9'	5,200	55°	106.0'	3,900	121.0'	3,100	124.0'	2,800
50°	98.2'	5,000	105.0'	4,600	107.0'	4,500	50°	118.0'	3,300	131.0'	2,800	132.0'	2,700
45°	107.0'	4,300	113.0'	4,100	114.0'	4,000	45°	128.0'	2,800	139.0'	2,600	140.0'	2,500
40°	115.0'	3,800	120.0'	3,600			40°	137.0'	2,400	147.0'	2,300		
35°	122.0'	3,400	127.0'	3,300			35°	145.0'	2,100	153.0'	2,000		
30°	129.0'	3,100	132.0'	3,000			30°	153.0'	1,900	159.0'	1,800		
25°	134.0'	2,800	137.0'	2,800			25°	159.0'	1,700	163.0'	1,700		
20°	139.0'	2,650					20°	164.0'	1,550				
15°	142.0'	2,500					15°	168.0'	1,450				

C :Loaded boom angle (deg.)  
R :Load radius in feet  
W :Rated lifting capacity in pounds

# TR-800XXL RATED LIFTING CAPACITIES (IN POUNDS)

ON OUTRIGGERS MID. EXTENDED 21' 11-3/4" (6.7m) SPREAD																					
360° ROTATION																					
B \ A	37.7'		51'		64.4' (19.62m)				91' (27.75m)			117.7' (35.87m)			131'		144.4'				
	C	(11.5m)	C	(15.56m)	C	C	C	C	C	C	C	C	C	C	C	(39.93m)	C	(44.0m)			
10'	68°	160,000	75°	103,600	78°	88,100	78°	44,000													
12'	65°	125,000	72°	103,600	76°	88,100	76°	44,000													
15'	60°	108,000	69°	103,600	73°	88,100	73°	44,000	79°	44,000	79°	30,800									
20'	50°	78,400	63°	77,800	69°	71,900	69°	44,000	76°	44,000	76°	30,800	79°	30,800	79°	17,600					
25'	38°	59,400	56°	56,100	64°	55,200	64°	44,000	73°	44,000	73°	30,800	77°	30,800	77°	17,600	79°	17,600	80°	17,600	
30'	21°	40,300	48°	39,200	59°	38,400	59°	44,000	70°	39,000	70°	26,700	75°	30,800	75°	17,600	77°	17,600	78°	17,600	
35'			39°	29,000	53°	28,200	53°	35,200	66°	32,000	66°	23,200	72°	28,200	72°	17,600	75°	17,600	76°	17,600	
40'			28°	22,200	47°	21,400	47°	27,600	63°	24,900	63°	20,400	70°	24,700	70°	17,600	73°	17,600	74°	17,600	
45'			5°	17,000	40°	16,500	40°	22,200	59°	19,800	59°	18,200	67°	21,800	67°	16,400	71°	17,600	73°	17,600	
50'					32°	12,800	32°	18,000	55°	15,900	56°	16,400	64°	17,800	64°	14,700	68°	16,200	71°	17,100	
60'									46°	10,500	47°	14,500	59°	11,900	59°	11,900	63°	13,300	66°	12,800	
70'									36°	6,800	37°	9,900	52°	8,000	53°	9,900	58°	9,600	61°	8,900	
80'									22°	4,200	24°	7,100	45°	5,200	46°	7,800	52°	6,800	56°	6,100	
90'													37°	3,200	38°	5,700	46°	4,700	51°	4,000	
100'													27°	1,600	28°	4,100	39°	3,100	45°	2,400	
110'															13°	2,800	30°	1,900	39°	1,200	
<b>D</b>	0°					27°			0°		30°		39°								
Telescoping conditions (%)																					
Telescoping mode	I, II		I		I		II		I		II		I		II		II		I, II		
2nd boom	0		50		100		0		100		0		100		0		50		100		
3rd boom	0		0		0		33		33		66		66		100		100		100		
4th boom	0		0		0		33		33		66		66		100		100		100		
Top boom	0		0		0		33		33		66		66		100		100		100		

LIFTING CAPACITIES AT ZERO DEGREE BOOM ANGLE ON OUTRIGGERS MID. EXTENDED																		
21' 11-3/4" (6.7m) SPREAD 360° ROTATION																		
C \ A	37.7'		51'		64.4'		64.4'		91'		91'		117.7'					
	B	(11.5m)	B	(15.56m)	B	(19.62m)	B	(19.62m)	B	(27.75m)	B	(27.75m)	B	(35.87m)				
0°	31.7'	36,400	45.0'	17,000	58.3'	9,000	58.3'	14,300	85.0'	3,200	85.0'	6,000		111.6'	2,500			
Telescoping mode	I, II		I		I		II		I		II		II					

- A :Boom length in feet
- B :Load radius in feet
- C :Loaded boom angle (deg.)
- D :Minimum boom angle (deg.) for indicated length (no load)

NOTE: -The lifting capacity data stored in the LOAD MOMENT INDICATOR (AML-L) is based on the standard number of parts of line listed in the chart.  
 -Standard number of parts of line for outrigger operation should be according to the following table.

Boom Length in Feet (meters)	37.7' (11.5m)	37.7' to 51' (11.5m to 15.56m)	51' to 64.4' (15.56m to 19.62m)	64.4' to 91' (19.62m to 27.75m)	91' to 144.4' (27.75m to 44.0m)	Single top Jib
Number of parts of line	16	12	10	5	4	1



# TR-800XXL RATED LIFTING CAPACITIES (IN POUNDS)

ON OUTRIGGERS MID. EXTENDED 21' 11-3/4" (6.7m) SPREAD 360° ROTATION													
C	144.4' (44.0m) Boom + 32.5' (9.9m) Jib						C	144.4' (44.0m) Boom + 58.1' (17.7m) Jib					
	3.5° offset		25° offset		45° offset			3.5° offset		25° offset		45° offset	
	R	W	R	W	R	W		R	W	R	W	R	W
80°	32.7'	9,900	44.5'	8,800	52.7'	8,100	80°	40.6'	5,900	64.3'	5,400	73.5'	3,400
75°	50.3'	9,900	61.2'	8,700	67.6'	7,300	75°	60.6'	5,900	82.5'	4,800	89.9'	3,400
70°	66.4'	9,700	75.9'	7,600	81.2'	6,600	70°	79.3'	5,900	98.7'	4,200	105.0'	3,400
65°	80.0'	7,200	89.3'	6,600	93.9'	6,000	65°	95.6'	4,900	114.0'	3,700	118.0'	3,100
60°	92.4'	4,700	101.0'	4,400	105.0'	4,100	60°	110.0'	3,400	127.0'	2,800	130.0'	2,500
55°	104.0'	2,900	112.0'	2,700	115.0'	2,600	55°	123.0'	1,800	138.0'	1,500	141.0'	1,400
50°	115.0'	1,600	122.0'	1,500	124.0'	1,500							

ON OUTRIGGERS MID. EXTENDED 21' 11-3/4" (6.7m) SPREAD 360° ROTATION													
C	117.7' (35.87m) Boom (telescoping mode I) + 32.5' (9.9m) Jib						C	117.7' (35.87m) Boom (telescoping mode I) + 58.1' (17.7m) Jib					
	3.5° offset		25° offset		45° offset			3.5° offset		25° offset		45° offset	
	R	W	R	W	R	W		R	W	R	W	R	W
80°	26.1'	12,300	37.7'	11,000	44.8'	8,400	80°	33.6'	7,900	55.1'	5,700	67.0'	3,700
75°	40.1'	12,300	50.7'	10,000	57.0'	8,000	75°	50.4'	7,900	70.3'	5,200	80.7'	3,700
70°	53.6'	12,100	62.9'	8,800	68.5'	7,400	70°	65.9'	7,100	84.4'	4,700	93.1'	3,600
65°	65.7'	9,900	74.6'	7,700	79.0'	6,700	65°	80.2'	6,000	97.2'	4,200	104.0'	3,500
60°	76.9'	8,100	85.2'	6,800	88.9'	6,200	60°	93.5'	5,100	109.0'	3,800	114.0'	3,300
55°	87.2'	5,700	94.8'	5,100	97.7'	4,700	55°	105.0'	3,800	120.0'	3,300	124.0'	3,000
50°	96.8'	3,900	104.0'	3,500	106.0'	3,400	50°	116.0'	2,500	129.0'	2,100	132.0'	2,000
45°	106.0'	2,600	112.0'	2,300	113.0'	2,300	45°	126.0'	1,400	138.0'	1,300	139.0'	1,200
40°	114.0'	1,600	119.0'	1,400									

ON OUTRIGGERS MID. EXTENDED 21' 11-3/4" (6.7m) SPREAD 360° ROTATION													
C	117.7' (35.87m) Boom (telescoping mode II) + 32.5' (9.9m) Jib						C	117.7' (35.87m) Boom (telescoping mode II) + 58.1' (17.7m) Jib					
	3.5° offset		25° offset		45° offset			3.5° offset		25° offset		45° offset	
	R	W	R	W	R	W		R	W	R	W	R	W
80°	26.8'	11,000	39.1'	10,300	46.6'	8,300	80°	34.2'	6,300	56.8'	5,700	67.7'	3,700
75°	41.0'	11,000	52.3'	9,300	58.8'	7,700	75°	51.0'	6,300	71.7'	5,100	81.4'	3,700
70°	54.5'	10,600	64.5'	8,000	70.1'	6,900	70°	67.0'	6,300	85.4'	4,400	93.8'	3,600
65°	66.3'	8,600	75.9'	7,000	80.4'	6,200	65°	80.9'	5,300	98.4'	3,900	105.0'	3,300
60°	77.6'	7,100	86.6'	6,200	90.2'	5,700	60°	94.2'	4,500	110.0'	3,500	115.0'	3,000
55°	88.4'	5,900	96.5'	5,300	98.9'	5,200	55°	106.0'	3,900	121.0'	3,100	124.0'	2,800
50°	98.2'	5,000	105.0'	4,600	107.0'	4,500	50°	118.0'	3,300	131.0'	2,800	132.0'	2,700
45°	107.0'	4,300	113.0'	4,100	114.0'	4,000	45°	128.0'	2,800	139.0'	2,600	140.0'	2,500
40°	115.0'	3,400	120.0'	3,300			40°	137.0'	2,100	146.0'	2,000		
35°	122.0'	2,700	126.0'	2,600			35°	145.0'	1,500	153.0'	1,400		
30°	128.0'	2,100	132.0'	2,100			30°	152.0'	1,100				
25°	134.0'	1,700	137.0'	1,700									
20°	138.0'	1,400											
15°	142.0'	1,200											

C :Loaded boom angle (deg.)  
R :Load radius in feet  
W :Rated lifting capacity in pounds

# TR-800XXL RATED LIFTING CAPACITIES (IN POUNDS)

ON OUTRIGGERS MID. EXTENDED 18' 1/2" (5.5m) SPREAD																				
360° ROTATION																				
B \ A	37.7'		51'		64.4' (19.62m)		91' (27.75m)		117.7' (35.87m)		131'	144.4'								
	C	(11.5m)	C	(15.56m)	C	C	C	C	C	C	(39.93m)	(44.0m)								
10'	68°	160,000	75°	103,600	78°	88,100	78°	44,000												
12'	65°	125,000	72°	103,600	76°	88,100	76°	44,000												
15'	60°	108,000	69°	103,600	73°	88,100	73°	44,000	79°	44,000	79°	30,800								
20'	50°	64,600	62°	62,400	69°	61,500	69°	44,000	76°	44,000	76°	30,800	79°	30,800	79°	17,600				
25'	38°	42,600	56°	41,400	64°	40,600	64°	44,000	73°	43,500	73°	30,800	77°	30,800	77°	17,600	79°	17,600	80°	17,600
30'	21°	29,100	48°	30,300	59°	28,200	59°	34,200	70°	31,600	70°	26,700	75°	30,800	75°	17,600	77°	17,600	78°	17,600
35'			39°	21,100	53°	20,300	53°	26,100	66°	23,700	66°	23,200	72°	26,100	72°	17,600	75°	17,600	76°	17,600
40'			28°	15,700	47°	15,000	47°	20,500	62°	18,200	63°	20,400	70°	20,300	70°	17,600	73°	17,600	74°	17,600
45'			5°	11,600	40°	11,000	40°	16,300	59°	14,200	59°	18,000	67°	16,100	67°	16,400	71°	17,600	73°	16,900
50'					32°	8,000	32°	13,100	55°	11,100	55°	14,700	64°	12,800	64°	14,700	68°	14,700	70°	13,600
60'									46°	6,600	46°	10,000	58°	8,100	59°	10,900	63°	9,900	66°	8,900
70'									36°	3,500	36°	6,800	52°	4,900	52°	7,600	57°	6,700	61°	5,700
80'									21°	1,400	23°	4,600	45°	2,700	45°	5,300	52°	4,300	56°	3,500
90'															37°	3,500	45°	2,600	50°	1,800
100'															27°	2,200	38°	1,200		
110'															12°	1,100				
D	0°								41°		12°		38°		50°					
Telescoping conditions (%)																				
Telescoping mode	I, II	I	I	I	II	I	II	I	II	I	II	I, II								
2nd boom	0	50	100	0	100	0	100	0	100	0	50	100								
3rd boom	0	0	0	33	33	66	66	100	100	100	100	100								
4th boom	0	0	0	33	33	66	66	100	100	100	100	100								
Top boom	0	0	0	33	33	66	66	100	100	100	100	100								

LIFTING CAPACITIES AT ZERO DEGREE BOOM ANGLE ON OUTRIGGERS MID. EXTENDED												
18' 1/2" (5.5m) SPREAD 360° ROTATION												
C \ A	37.7'		51'		64.4'		64.4'		91'		91'	
	B	(11.5m)	B	(15.56m)	B	(19.62m)	B	(19.62m)	B	(27.75m)	B	(27.75m)
0°	31.7'	26,400	45.0'	11,600	58.3'	5,000	58.3'	9,700	85.0'	1,100	85.0'	3,700
Telescoping mode	I, II	I	I	I	II	I	II	I	II			

- A : Boom length in feet
- B : Load radius in feet
- C : Loaded boom angle (deg.)
- D : Minimum boom angle (deg.) for indicated length (no load)

NOTE: -The lifting capacity data stored in the LOAD MOMENT INDICATOR (AML-L) is based on the standard number of parts of line listed in the chart.

-Standard number of parts of line for outrigger operation should be according to the following table.

Boom Length in Feet (meters)	37.7' (11.5m)	37.7' to 51' (11.5m to 15.56m)	51' to 64.4' (15.56m to 19.62m)	64.4' to 91' (19.62m to 27.75m)	91' to 144.4' (27.75m to 44.0m)	Single top Jib
Number of parts of line	16	12	10	5	4	1

# TR-800XXL RATED LIFTING CAPACITIES (IN POUNDS)

ON OUTRIGGERS MID. EXTENDED 18' 1/2" (5.5m) SPREAD 360° ROTATION													
C	144.4' (44.0m) Boom + 32.5' (9.9m) Jib						C	144.4' (44.0m) Boom + 58.1' (17.7m) Jib					
	3.5° offset		25° offset		45° offset			3.5° offset		25° offset		45° offset	
	R	W	R	W	R	W		R	W	R	W	R	W
80°	32.7'	9,900	44.5'	8,800	52.7'	8,100	80°	40.6'	5,900	64.3'	5,400	73.5'	3,400
75°	50.3'	9,900	61.2'	8,700	67.6'	7,300	75°	60.6'	5,900	82.5'	4,800	89.9'	3,400
70°	65.3'	8,000	75.0'	6,700	80.9'	6,300	70°	78.6'	5,400	98.7'	4,200	105.0'	3,400
65°	78.3'	5,000	87.5'	4,100	92.5'	4,000	65°	93.2'	3,100	112.0'	2,800	117.0'	2,400
60°	90.9'	2,800	99.2'	2,300	103.0'	2,300	60°	107.0'	1,500	125.0'	1,300	129.0'	1,100
55°	102.0'	1,300	111.0'	1,100	114.0'	1,100							

ON OUTRIGGERS MID. EXTENDED 18' 1/2" (5.5m) SPREAD 360° ROTATION													
C	117.7' (35.87m) Boom (telescoping mode I) + 32.5' (9.9m) Jib						C	117.7' (35.87m) Boom (telescoping mode I) + 58.1' (17.7m) Jib					
	3.5° offset		25° offset		45° offset			3.5° offset		25° offset		45° offset	
	R	W	R	W	R	W		R	W	R	W	R	W
80°	26.1'	12,300	37.7'	11,000	44.8'	8,400	80°	33.6'	7,900	55.1'	5,700	67.0'	3,700
75°	40.1'	12,300	50.7'	10,000	57.0'	8,000	75°	50.4'	7,900	70.3'	5,200	80.7'	3,700
70°	53.1'	11,000	62.9'	8,800	68.5'	7,400	70°	65.9'	7,100	84.4'	4,700	93.1'	3,600
65°	65.0'	8,100	74.4'	7,300	78.9'	6,200	65°	79.9'	5,700	97.2'	4,200	104.0'	3,500
60°	75.6'	5,300	84.4'	4,800	88.4'	4,200	60°	92.0'	3,500	108.0'	3,000	114.0'	2,600
55°	86.2'	3,300	94.0'	3,000	97.2'	2,700	55°	104.0'	1,900	119.0'	1,700	123.0'	1,500
50°	95.8'	1,800	103.0'	1,700	105.0'	1,600							

ON OUTRIGGERS MID. EXTENDED 18' 1/2" (5.5m) SPREAD 360° ROTATION													
C	117.7' (35.87m) Boom (telescoping mode II) + 32.5' (9.9m) Jib						C	117.7' (35.87m) Boom (telescoping mode II) + 58.1' (17.7m) Jib					
	3.5° offset		25° offset		45° offset			3.5° offset		25° offset		45° offset	
	R	W	R	W	R	W		R	W	R	W	R	W
80°	26.8'	11,000	39.1'	10,300	46.6'	8,300	80°	34.2'	6,300	56.8'	5,700	67.7'	3,700
75°	41.0'	11,000	52.3'	9,300	58.8'	7,700	75°	51.0'	6,300	71.7'	5,100	81.4'	3,700
70°	54.5'	10,600	64.5'	8,000	70.1'	6,900	70°	67.0'	6,300	85.4'	4,400	93.8'	3,600
65°	66.3'	8,600	75.9'	7,000	80.4'	6,200	65°	80.9'	5,300	98.4'	3,900	105.0'	3,300
60°	77.5'	7,000	86.6'	6,200	90.2'	5,700	60°	94.2'	4,500	110.0'	3,500	115.0'	3,000
55°	87.8'	5,000	96.0'	4,700	98.5'	4,300	55°	106.0'	3,500	121.0'	3,000	124.0'	2,700
50°	97.4'	3,600	104.0'	3,400	106.0'	3,200	50°	117.0'	2,300	130.0'	2,000	132.0'	1,800
45°	106.0'	2,500	112.0'	2,500	114.0'	2,300	45°	127.0'	1,500	138.0'	1,300	139.0'	1,200
40°	114.0'	1,700	119.0'	1,700									
35°	121.0'	1,200	126.0'	1,100									

**C** :Loaded boom angle (deg.)  
**R** :Load radius in feet  
**W** :Rated lifting capacity in pounds

# TR-800XXL RATED LIFTING CAPACITIES (IN POUNDS)

ON OUTRIGGERS MIN. EXTENDED 9' 2-1/4"(2.8m) SPREAD																					
360° ROTATION																					
A	37.7'		51'		64.4' (19.62m)			91' (27.75m)			117.7' (35.87m)		131'	144.4'							
	C	(11.5m)	C	(15.56m)	C	C	C	C	C	C	C	C	(39.93m)	C	(44.0m)						
10'	68°	84,100	75°	77,900	78°	76,000	78°	44,000													
12'	65°	62,000	72°	58,200	76°	56,800	76°	44,000													
15'	60°	42,400	68°	40,000	73°	39,000	73°	43,800	79°	41,700	79°	30,800									
20'	50°	25,700	62°	23,900	69°	23,200	69°	28,700	76°	26,600	76°	30,500	79°	28,400	79°	17,600					
25'	38°	16,800	55°	15,300	64°	14,600	64°	19,900	72°	17,800	72°	21,600	77°	19,500	77°	17,600					
30'	21°	11,000	48°	9,900	59°	9,200	58°	14,300	69°	12,400	69°	15,900	74°	13,900	75°	16,600					
35'			39°	6,200	53°	5,500	53°	10,400	65°	8,600	66°	11,900	72°	9,900	72°	12,700					
40'			28°	3,400	47°	2,800	47°	7,400	62°	5,600	62°	8,900	69°	6,900	69°	9,600					
45'			5°	1,300			40°	5,200	58°	3,400	58°	6,700	66°	4,700	66°	7,300					
50'							32°	3,400	54°	1,700	54°	4,900	63°	2,900	64°	5,600					
60'															58°	3,000					
70'															51°	1,200					
D	0°		44°			0°			54°			43°		61°		51°		61°		65°	
Telescoping conditions (%)																					
Telescoping mode	I, II		I		I			II			I		II		II		I, II				
2nd boom	0		50		100			0			100		0		50		100				
3rd boom	0		0		0			33			33		66		66		100				
4th boom	0		0		0			33			33		66		66		100				
Top boom	0		0		0			33			33		66		66		100				

LIFTING CAPACITIES AT ZERO DEGREE BOOM ANGLE ON OUTRIGGERS MIN. EXTENDED												
9' 2-1/4" (2.8m) SPREAD 360° ROTATION												
A	37.7'		51'		64.4'							
	B	(11.5m)	B	(15.56m)	B			B			B	
0°	31.7'	9,400	45.0'	1,300	58.3'			1,700				
Telescoping mode	I, II		I					II				

- A : Boom length in feet
- B : Load radius in feet
- C : Loaded boom angle (deg.)
- D : Minimum boom angle (deg.) for indicated length (no load)

NOTE: -The lifting capacity data stored in the LOAD MOMENT INDICATOR (AML-L) is based on the standard number of parts of line listed in the chart.

-Standard number of parts of line for outrigger operation should be according to the following table.

Boom Length in Feet (meters)	37.7' (11.5m)	37.7' to 51' (11.5m to 15.56m)	51' to 64.4' (15.56m to 19.62m)	64.4' to 91' (19.62m to 27.75m)	91' to 144.4' (27.75m to 44.0m)	Single top Jib
Number of parts of line	16	12	10	5	4	1

# WARNING AND OPERATING INSTRUCTIONS FOR LIFTING CAPACITIES

## GENERAL

1. RATED LIFTING CAPACITIES apply only to the machine as originally manufactured and normally equipped by TADANO LTD. Modifications to the machine or use of optional equipment other than that specified can result in a reduction of capacity.
2. Hydraulic cranes can be hazardous if improperly operated or maintained. Operation and maintenance of this crane must be in compliance with information in the **Operation and Maintenance Manual** supplied with the crane. If this manual is missing, order a replacement through the distributor.
3. The operator and other personnel associated with this machine shall fully acquaint themselves with the latest American National Standards Institute (ANSI) safety standards for cranes.

## SET UP

1. Rated lifting capacities on the chart are the maximum allowable crane capacities and are based on the machine standing level on firm supporting surface under ideal job conditions. Depending on the nature of the supporting surface, it may be necessary to have structural supports under the outrigger floats or tires to spread the loads to a larger bearing surface.
2. For outrigger operation, outriggers shall be properly extended with tires free of supporting surface before operating crane.

## OPERATION

1. Rated lifting capacities have been tested to and meet minimum requirements of SAE J1063-Cantilevered Boom Crane Structures Method of Test.
2. Rated lifting capacities do not exceed 85 % of the tipping load on outriggers fully extended as determined by SAE J765-Crane Stability Test Code.  
Rated lifting capacities for partially extended outriggers are determined by this formula, Rated Lifting Capacities = (Tipping Load - 0.1 x Tip Reaction) / 1.25.
3. Rated lifting capacities above bold lines in the chart are based on crane strength and those below, on its stability. They are based on actual load radius increased by boom deflection.
4. The weight of handling device such as hook blocks, slings, etc., must be considered as part of the load and must be deducted from the lifting capacities.
5. Rated lifting capacities are based on freely suspended loads and make no allowance for such factors as the effect of wind sudden stopping of loads, supporting surface conditions, inflation of tires, operating speeds, side loads, etc. Side pull on boom or jib is extremely dangerous
6. Rated lifting capacities do not account for the effects of wind on a lifted load or boom. Rated lifting capacities and boom length shall be appropriately reduced, when wind velocity exceeds 20 mph (9 m/sec.).
7. Rated lifting capacities at load radius shall not be exceeded. Do not tip the crane to determine allowable loads
8. Do not operate at boom lengths, radii, or boom angle, where no capacities are shown. Crane may overturn without any load on the hook.
9. When boom length is between values listed, refer to the rated lifting capacities of the next longer and next shorter booms for the same radius. The lesser of the two rated lifting capacities shall be used

10. When making lifts at a load radius not shown, use the next longer radius to determine allowable capacity
11. Load per line should not exceed 12,300 lbs. (5,600kg) for main winch and auxiliary winch.
12. Check the actual number of parts of line with LOAD MOMENT INDICATOR (AML-L) before operation. Maximum lifting capacity is restricted by the number of parts of line of LOAD MOMENT INDICATOR (AML-L). Limited capacity is as determined from the formula, Single line pull for main winch (12,300 lbs.) x number of parts of line.
13. The boom angle before loading should be greater to account for deflection. For rated lifting capacities, the loaded boom angle and the load radius is for reference only.
14. The 37.7' (11.5m) boom length capacities are based on boom fully retracted. If not fully retracted [less than 51' (15.56m) boom length], use the rated lifting capacities for the 51' (15.56m) boom length.
15. Extension or retraction of the boom with loads may be attempted within the limits of the RATED LIFTING CAPACITIES. The ability to telescope loads is limited by hydraulic pressure boom angle, boom length, crane maintenance, etc.
16. For lifting capacity of single top, reduce the rated lifting capacities of relevant boom according to a weight reductions for auxiliary load handling equipment. Capacities of single top shall not exceed 12,300 lbs. (5,600kg) including main hook.
17. When base jib or top jib or both jib removing, jib state switch select removed.
18. When erecting and stowing jib, be sure to retain it by hand or by other means to prevent its free movement.
19. Use "ANTI-TWO BLOCK" disable switch when erecting and stowing jib and when stowing hook block. While the switch is pushed, the hoist does not stop, even when overwind condition occurs.
20. For boom length with 32.5' (9.9m) jib, rated lifting capacities are determined by loaded boom angle only in the column headed "144.4' (44.0m) boom + 32.5' (9.9m) jib".  
For boom length with 58.1' (17.7 m) jib, rated lifting capacities are determined by loaded boom angle only in the column headed "144.4' (44.0m) boom + 58.1' (17.7m) jib".  
For angles not shown, use the next lower loaded boom angle to determine allowable capacity.
21. When lifting a load by using jib (aux. winch) and boom (main winch) simultaneously, do the following
  - Enter the operation status as jib operation, not as boom operation.
  - Before starting operation, make sure that mass of load is within rated lifting capacity for jib.

## DEFINITIONS

1. Load Radius: Horizontal distance from a projection of the axis of rotation to supporting surface before loading to the center of the vertical hoist line or tackle with load applied.
2. Loaded Boom Angle: The angle between the boom base section and the horizontal, after lifting the rated lifting capacity at the load radius.
3. Working Area: Area measured in a circular arc about the centerline of rotation.
4. Freely Suspended Load: Load hanging free with no direct external force applied except by the hoist line.
5. Side Load: Horizontal side force applied to the lifted load either on the ground or in the air.

# TR-800XXL RATED LIFTING CAPACITIES (IN POUNDS)

ON RUBBER																		
A	Stationary						Creep											
	OVER FRONT			360° ROTATION			OVER FRONT											
	37.7'	64.4'	91'	37.7'	64.4'	91'	37.7'	64.4'	91'									
B	C (11.5m)	C (19.62m)	C (27.75m)	C (11.5m)	C (19.62m)	C (27.75m)	C (11.5m)	C (19.62m)	C (27.75m)									
10'	68°	71,200			68°	49,500		68°	55,200									
12'	65°	62,200			65°	41,700		65°	47,800									
15'	59°	51,600			59°	29,400		59°	39,200									
20'	50°	39,400	69°	35,300	50°	18,000	69°	21,300	50°	29,000	69°	31,900						
25'	38°	28,000	64°	29,400	38°	11,600	64°	14,700	38°	22,200	64°	25,200						
30'	21°	20,300	59°	23,600	69°	22,100	21°	7,600	58°	10,600	69°	10,600	21°	17,200	59°	20,200	69°	21,200
35'			53°	18,100	66°	19,100			53°	7,500	65°	7,800			53°	16,500	66°	17,500
40'			47°	14,300	62°	15,300			47°	5,300	62°	5,800			47°	13,500	62°	14,600
45'			40°	11,200	59°	12,400			40°	3,600	58°	4,200			40°	11,100	59°	12,200
50'			32°	9,000	55°	10,000			32°	2,300	54°	3,000			32°	9,000	55°	10,000
55'			21°	7,100	50°	8,200			21°	1,200	50°	2,100			21°	7,100	50°	8,200
60'					46°	6,600					45°	1,300					46°	6,600
65'					41°	5,400											41°	5,400
70'					36°	4,300											36°	4,300
75'					29°	3,400											29°	3,400
80'					22°	2,700											22°	2,700
D	0°			0°			21°		45°		0°							
Telescoping conditions (%)																		
Telescoping mode	I, II	II	II	I, II	II	II	I, II	II	II									
2nd boom	0	0	0	0	0	0	0	0	0	0								
3rd boom	0	33	66	0	33	66	0	33	66	66								
4th boom	0	33	66	0	33	66	0	33	66	66								
Top boom	0	33	66	0	33	66	0	33	66	66								

LIFTING CAPACITIES AT ZERO DEGREE BOOM ANGLE ON RUBBER OPERATION														
A	Stationary						Creep							
	OVER FRONT			360° ROTATION			OVER FRONT							
	37.7'	64.4'	91'	37.7'	64.4'	91'	37.7'	64.4'	91'					
C	B (11.5m)	B (19.62m)	B (27.75m)	B (11.5m)	B (19.62m)	B (27.75m)	B (11.5m)	B (19.62m)	B (27.75m)					
0°	31.7'	18,600	58.3'	6,000	85.0'	1,900	31.7'	6,600	31.7'	16,100	58.3'	6,000	85.0'	1,900

- A :Boom length in feet
- B :Load radius in feet
- C :Loaded boom angle (deg.)
- D :Minimum boom angle (deg.) for indicated length (no load)

NOTE: -The lifting capacity data stored in the LOAD MOMENT INDICATOR (AML-L) is based on the standard number of parts of line listed in the chart.  
 -Standard number of parts of line for rubber operation should be according to the following table.

Boom Length in Feet (meters)	37.7' (11.5m)	37.7' to 91' (11.5m to 27.75m)	Single top Jib
Number of parts of line	6	4	1

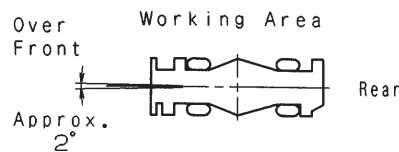

## WARNING AND OPERATING INSTRUCTIONS FOR ON RUBBER LIFTING CAPACITIES

- Rated lifting capacities on rubber are in pounds and do not exceed 75 % of tipping loads as determined by SAE J765-Crane Stability Test Code.
- Rated lifting capacities shown in the chart are based on condition that crane is set on firm level surfaces with axle oscillation lockout applied. Those above bold lines are based on tire capacity and those below, on crane stability. They are based on actual load radius increased by tire deformation and boom deflection.
- If the axle oscillation lockout cylinders contain air, the axle will not be locked completely and rated lifting capacities may not be obtainable. Bleed the cylinders according to the operation safety and maintenance manual.
- Rated lifting capacities are based on proper tire inflation, capacity and condition. Damaged tires are hazardous to safe operation of crane.
- Tires shall be inflated to correct air pressure.
- Over front operation shall be performed within two degrees in front of chassis.
- On rubber lifting with "jib" is not permitted. Maximum permissible boom length is 91 ft. (27.75m).
- When making lift on rubber stationary, set parking brake.
- For creep operation, boom must be centered over front of machine, swing lock engaged, and load restrained from swinging. Travel slowly and keep the lifted load as close to the ground as possible, and especially avoid any abrupt steering, accelerating or braking.
- Do not operate the crane while carrying the load.
- Creep is motion for crane not to travel more than 200 ft. (60 m) in any 30 minute period and to travel at the speed of less than 1mph (1.6km/h).
- For creep operation, set Drive select switch to "4-WHEEL (Lo)" and set gear shift lever to "1".

Tires	Air Pressure
29.5-25 22PR	60 psi (4.2 kgf/cm <sup>2</sup> )
29.5-25 28PR	64 psi (4.5 kgf/cm <sup>2</sup> )

# WARNING AND OPERATING INSTRUCTIONS FOR USING THE LOAD MOMENT INDICATOR (AML-L)

1. When operating crane on outriggers:
  - Set P.T.O. switch to "ON".
  - Press the outrigger mode select key to register for the outrigger operation. Press the register key, then the outrigger mode indicative symbol changes from flashing to a solid light.
  - Press the lift mode select key to select the lift status that corresponds to the actual boom configuration. Each time the lift mode select key is pressed, the status changes. Press the register key to register the lift status, then the lift indicative symbol changes from flashing to a solid light.
  - When mounting and stowing jib, select the jib set status (jib state indicative symbol flicker).
2. When operating crane on rubber:
  - Set P.T.O. switch to "ON".
  - Press the outrigger mode select key. The on-tire mode indicative symbol comes on. Each time the outrigger mode select key is pressed the mode changes. Select the creep operation, the on-tire mode indicative symbol flicker.
  - Press the lift mode select key to register the boom mode. However, pay attention to the following.
    - (1) For stationary operation.
      - The front capacities are attainable only when the over front position symbol comes on. When the boom is more than 2 degrees from centered over front of chassis, 360° capacities are in effect.
      - When a load is lifted in the front position and then swung to the side area, make sure the value of the LOAD MOMENT INDICATOR(AML-L) is below the 360° lifting capacity.
    - (2) For creep operation.
      - The creep capacities are attainable only when boom is in the straight forward position of chassis and the over front position symbol is on. If boom is not in the straight forward position of chassis , never lift load.
3. This crane is equipped with an automatic swing stopping device.(For the details,see Operation & Maintenance Manual.) However, operate very carefully because the automatic swing stop does not work in the following cases.
  - When the "SWING STOP OVERRIDE" switch is turned on.
  - During on - tire operation.
  - When the "P.T.O." switch is set to "OVERRIDE" and the "AML OVERRIDE" key switch outside the cab is ON.
4. During crane operation, make sure that the displays on front panel are in accordance with actual operating conditions.
5. The displayed values of LOAD MOMENT INDICATOR (AML-L) are based on freely suspended loads and make no allowance for such factors as the effect of wind, sudden stopping of loads, supporting surface conditions, inflation of tire, operating speed, side loads, etc. For safe operation, it is recommended when extending and lowering boom or swinging, lifting loads shall be appropriately reduced.
6. LOAD MOMENT INDICATOR (AML-L) is intended as an aid to the operator. Under no condition should it be relied upon to replace use of capacity charts and operating instruction. Sole reliance upon LOAD MOMENT INDICATOR (AML-L) aids in place of good operating practice can cause an accident. The operator must exercise caution to assure safety.

## TR-800XXL-4 Axle weight distribution chart

	Pounds			Kilograms		
	GVW	Front	Rear	GVW	Front	Rear
Base machine	107,965	57,781	50,185	48,972	26,209	22,763
Remove:						
1. 80 ton (72.6 metric ton) hook block	-1,817	-3,276	1,459	-824	-1,486	662
2. 6.2 ton (5.6 metric ton) hook ball	-289	-401	112	-131	-182	51
3. Hot water cab heater and air conditioner	-214	-68	-146	-97	-31	-66
4. Top jib (25.6')	-677	-880	203	-307	-399	92
5. Base jib (32.5')	-1,832	-3,543	1,711	-831	-1,607	776
6. Auxiliary lifting sheave	-110	-324	214	-50	-147	97
7. Removable counterweight	-17,355	7,474	-24,828	-7,872	3,390	-11,262

